

PERMIT APPLICATION Guidelines for Decks

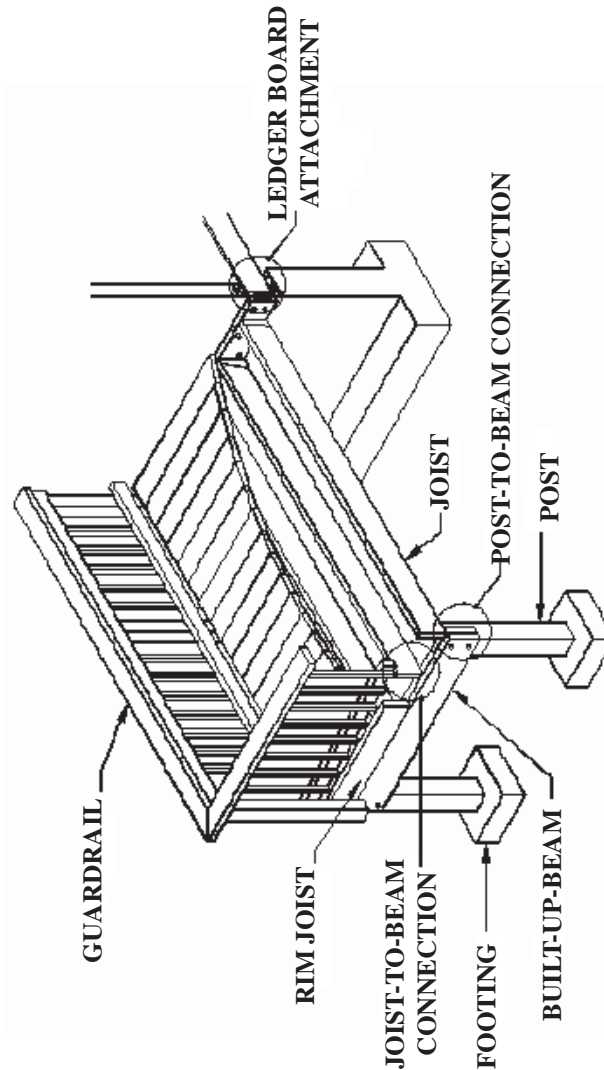

For further information, please contact the
Codes Administration Division at 913-742-6010



02/01/09

CITY OF SHAWNEE



11110 Johnson Drive
Shawnee, Kansas 66203
913-631-2500

A permit is required to construct any deck which will be more than 30+ inches above the adjoining ground level at any point. However, all decks are required to meet the minimum distance from property lines, (setbacks), as prescribed by the zoning ordinance.

All solid roofs which may be installed over a deck require a permit to construct.



Typical requirements for deck construction include the following:

- ◆ Footings shall extend to at least 36 inches below grade.
- ◆ The assumed allowable soil bearing pressure is 2000 psf.
- ◆ All lumber shall be treated lumber (such as ACQ) or wood of natural resistance to decay (such as cedar or heart of redwood).
- ◆ Floors shall be constructed to support not less than 40 pounds per square foot, in addition to the weight of materials.
- ◆ Guardrails shall be at least 36 inches high and shall have intermediate rails or patterns so constructed that there is no opening large enough to pass a 4 inch diameter ball through.
- ◆ A minimum ten (10) ft. vertical clearance and three (3) ft. horizontal clearance must be maintained from the new deck to any portion of overhead electrical wires.
- ◆ Handrails are required on all stairways with four (4) or more risers. Handrail grip sizes shall be 1.25" - 2" maximum cross section for circular profiles and 4" - 6.25" perimeter with a max cross section of 2.25" for non-circular cross sections. A 2 x 4 is not an acceptable handrail.
- ◆ The top of handrails along stairs should be 34" to 38" measured from the nosing of the tread. Guardrails shall be at least 34" high at stair treads more than 30" above grade.



The following information is required for a deck permit application:

1. A completed, signed permit application.
2. Two accurate, scaled plot plans, showing all structures on the property, (existing and proposed), and the distance from the deck to all property lines and structures.
3. Two foundation and framing plans, showing the sizes and location of all footings, support beams, and joists.
4. A check or cash for the building permit, collected at the time the permit is issued.
5. An occupational license is required for any contractor doing work in the City of Shawnee.

Should you need any reasonable accommodation to assist in making permit application, please contact the Codes Administration Division at 742-6010. You may access building permit guidelines for decks on-line at www.cityofshawnee.org.